

## Preparation Counter Chiller

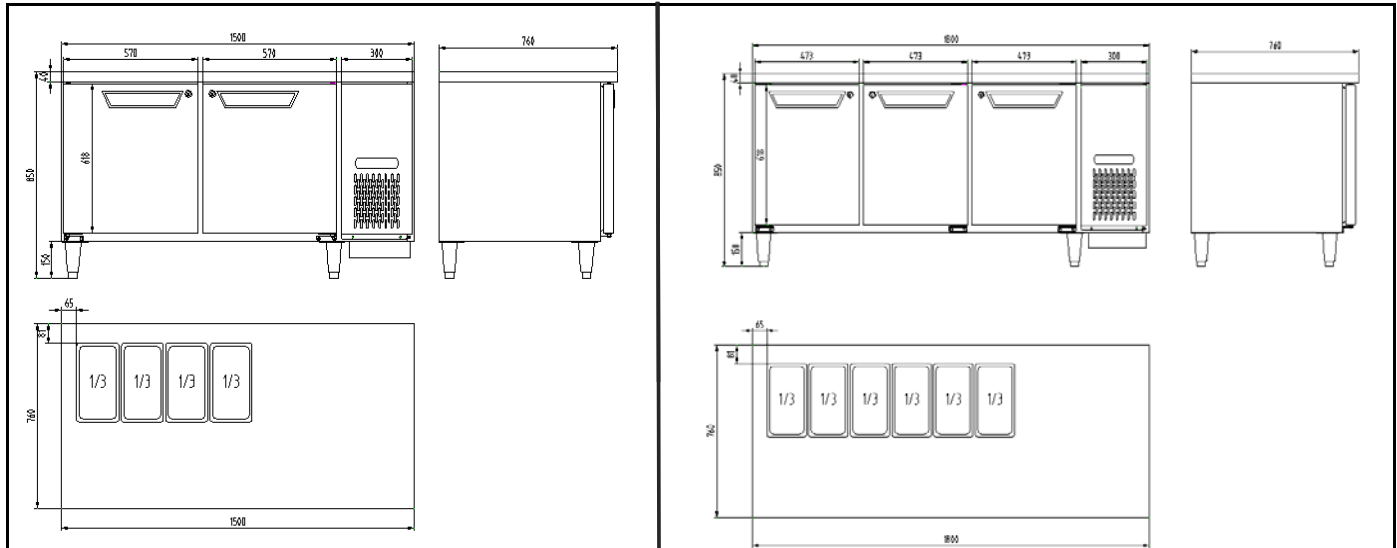

Model No.	External (mm) W*D*H	Capacity (L)	Nos. of GN pans	Operating Temp. (°C)	Rated(V) Current(A)	No. of shelves	Weight NW./GW.	Shipping dimension mm
CPA-150-N-SD	1500x760x850	380	4x1/3*100	+2~6	220V/2.8	2	105/109 kgs	1560*820*880
CPA-180-N-SD	1800x760x850	480	6x1/3*100	+2~6	220V/2.8	3	120/124 kgs	1860*820*880

### FEATURES:

#### REFRIGERATION SYSTEM

- Operating temperature: +2~6°C, under room temperature of 32°C.
- Fan forced evaporator cooling.
- Self-contained refrigeration system in the right side.
- Automatic evaporation of the defrost water by using the high pressure hot gas of the copper pipe.

#### CONSTRUCTION

- Designed to accommodate GN 1/3 pans (100mm deep) on top, interior accepts GN 1/1 pans.
- 55mm all round insulation with high density PU (40kg/m<sup>3</sup>).
- High quality international brand compressor: Embraco aspera compressor.
- The reduced dimension of compressor section provides a bigger inside space of the counter.
- Waterproof control panel easy to read and control.
- Door construction for compressor section for easy maintenance.
- Soft closing doors.
- Wide magnetic gasket gives effective seal and is removable for easy cleaning and maintenance.

#### OPTION

- Stainless steel splash-back to prevent spillage behind the counter.
- Internal lighting.
- Standard stainless steel bullet feet, adjustable from 135 to 165mm, castors with 130mm height is optional.